

FBR2500W - FBR2510W

PRV : 50 - 1000 Volts
Io : 25 Amperes

FEATURES :

- * High case dielectric strength
- * High surge current capability
- * High reliability
- * Low reverse current
- * Low forward voltage drop
- * Fast switching for high efficiency
- * Pb / RoHS Free

MECHANICAL DATA :

- * Case : Molded plastic with heatsink integrally mounted in the bridge encapsulation
- * Epoxy : UL94V-O rate flame retardant
- * Terminals : Plated lead solderable per MIL-STD-202, Method 208 guaranteed
- * Polarity : Polarity symbols marked on case
- * Mounting position : Bolt down on heat-sink with silicone thermal compound between bridge and mounting surface for maximum heat transfer efficiency
- * Weight : 15.95 grams

FAST RECOVERY BRIDGE RECTIFIERS

BR50W

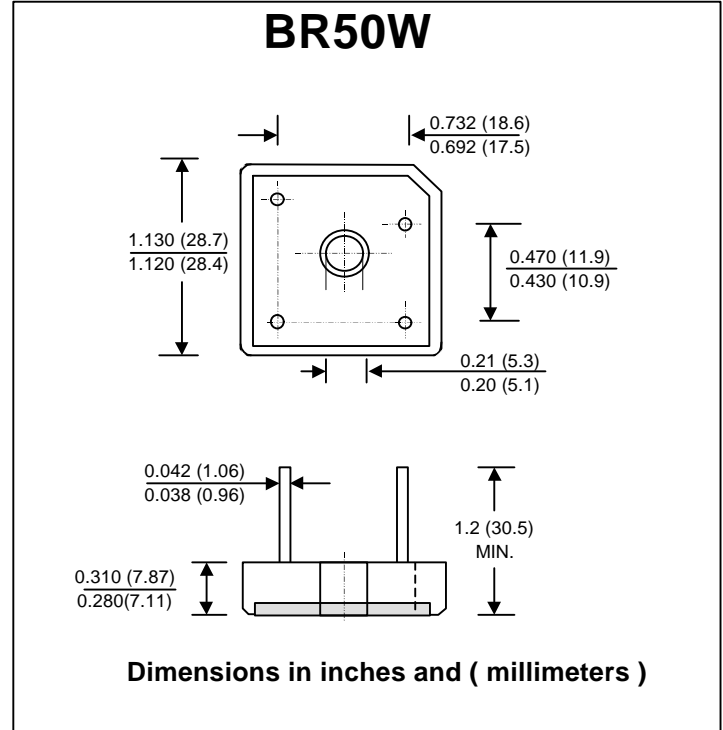

MAXIMUM RATINGS AND ELECTRICAL CHARACTERISTICS

Rating at 25 °C ambient temperature unless otherwise specified.
 Single phase, half wave, 60 Hz, resistive or inductive load.
 For capacitive load, derate current by 20%.

RATING	SYMBOL	FBR 2500W	FBR 2501W	FBR 2502W	FBR 2504W	FBR 2506W	FBR 2508W	FBR 2510W	UNIT
Maximum Recurrent Peak Reverse Voltage	V _{RRM}	50	100	200	400	600	800	1000	V
Maximum RMS Voltage	V _{RMS}	35	70	140	280	420	560	700	V
Maximum DC Blocking Voltage	V _{DC}	50	100	200	400	600	800	1000	V
Maximum Average Forward Current T _c = 55 °C	I _{F(AV)}	25							A
Peak Forward Surge Current Single half sine wave Superimposed on rated load (JEDEC Method)	I _{FSM}	300							A
Current Squared Time at t < 8.3 ms.	I ² t	375							A ² S
Maximum Forward Voltage drop per Diode at I _F = 12.5 A	V _F	1.3							V
Maximum DC Reverse Current Ta = 25 °C at Rated DC Blocking Voltage Ta = 100 °C	I _R	10							μA
	I _{R(H)}	200							μA
Maximum Reverse Recovery Time (Note 1)	T _{rr}	150				250	500		ns
Typical Thermal Resistance per diode (Note 2)	R _{θJC}	1.45							°C/W
Operating Junction Temperature Range	T _J	- 50 to + 150							°C
Storage Temperature Range	T _{STG}	- 50 to + 150							°C

Notes :

- 1) Measured with I_F = 0.5 Amp., I_R = 1 Amp., I_{rr} = 0.25 Amp.
- 2) Thermal Resistance from junction to case with units mounted on a 5" x 6" x 4.9" (12.8cm.x 15.2cm.x 12.4cm.) Al.-Finned Plate.

RATING AND CHARACTERISTIC CURVES (FBR2500W - FBR2510W)

FIG.1 - REVERSE RECOVERY TIME CHARACTERISTIC AND TEST CIRCUIT DIAGRAM

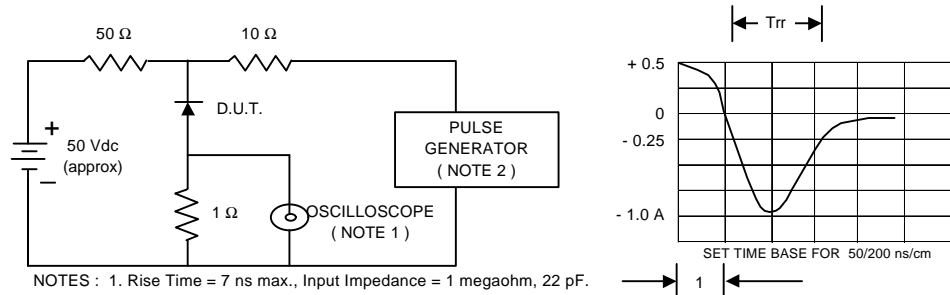

NOTES : 1. Rise Time = 7 ns max., Input Impedance = 1 megaohm, 22 pF.
 2. Rise time = 10 ns max., Source Impedance = 50 ohms.
 3. All Resistors = Non-inductive Types.

FIG.2 - DERATING CURVE FOR OUTPUT RECTIFIED CURRENT

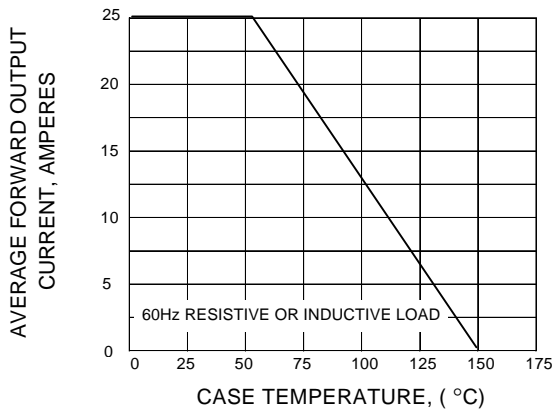

FIG.3 - MAXIMUM NON-REPETITIVE PEAK FORWARD SURGE CURRENT

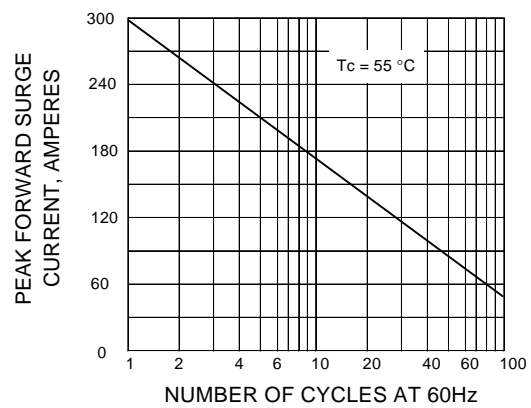

FIG.4 - TYPICAL FORWARD CHARACTERISTICS PER DIODE

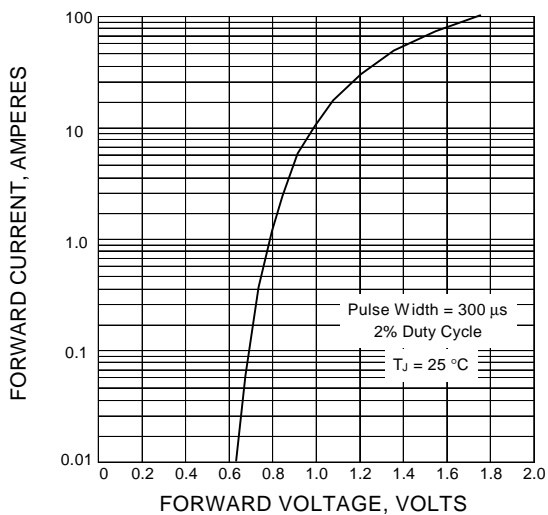

FIG.5 - TYPICAL REVERSE CHARACTERISTICS PER DIODE

